

# **HILTON AC-500 SOUND SYSTEM**

## **OPERATING INSTRUCTIONS**

Please read this manual carefully, and keep it in a safe place for future reference. It contains valuable information about your new Hilton AC-500 sound system: its features, how to operate it, how to take care of it, how to avoid damage to it, what to do if any problems should occur.

If you should encounter any problem in setting up or in operating your Hilton sound system, or if you have any question which is not answered in this manual, please write or phone.

### **HILTON AUDIO PRODUCTS, INC.**

1033-E SHARY CIRCLE - CONCORD, CA 94518  
PHONE (925) 682-8390 FAX (925) 682-8497  
e-mail: [HiltonAud@aol.com](mailto:HiltonAud@aol.com) Web Site: [www.hiltonaudio.com](http://www.hiltonaudio.com)

## **TABLE OF CONTENTS**

GUARANTEE OF SATISFACTION .....	Page 3
TOP DECK .....	Page 4
FRONT PANEL .....	Page 5
REAR PANEL .....	Page 9
SETUP AND OPERATION .....	Page 10
SPEAKER HOOKUP .....	Page 10
GETTING THE MOST FROM YOUR HILTON .....	Page 13
MAKING TAPE RECORDINGS .....	Page 14
PLAYING BACK TAPE RECORDINGS, CD's, & ? .....	Page 15
CORRECT HOOKUP FOR A SLAVE AMPLIFIER .....	Page 16
ROUTINE INSPECTION AND MAINTENANCE .....	Page 16
IN CASE OF TROUBLE .....	Page 18
REMOVING THE AMPLIFIER FROM THE CASE .....	Page 19
MULTIPLE SPEAKER HOOKUP DIAGRAMS .....	Page 20
POWER AMPLIFIER SCHEMATIC .....	Page 21
LED DISPLAY SCHEMATIC .....	Page 22
MICROPHONE PREAMPS SCHEMATIC .....	Page 23
POWER SUPPLY SCHEMATIC .....	Page 24
PHONO PREAMPS SCHEMATIC .....	Page 25
LIFTER SCHEMATIC .....	Page 26

## GUARANTEE OF SATISFACTION

Any purchaser of Hilton sound equipment, if not completely satisfied with it, may return such equipment in undamaged condition, freight charges prepaid, within 30 days after original purchase, for full refund of its purchase price.

## TWO-YEAR LIMITED WARRANTY

For a period of two years after initial purchase, Hilton Audio Products will, at its option, either repair or replace without charge any Hilton sound system or component thereof which fails in normal service, subject to the exceptions listed below. Any reasonable shipping and transit insurance charges, within the continental U.S.A., incurred in the course of warranty service will be paid by Hilton Audio Products.

### EXCEPTIONS TO WARRANTY:

Warranty is restricted to correction of any defect which becomes evident in the course of normal use and operation, and does not cover any of the following:

1. Replacement of phonograph needles, which are intrinsically fragile.
2. Repair of normal wear and tear: scratches, nicks, dents, etc.
3. Modernization or alteration to specifications which were not in effect at the time of original purchase.
4. Repair of damage which is caused by accident or abuse and not by any defect in the sound system.
5. Reimbursement for any repair charges not authorized by Hilton Audio Products.
6. Repair of damage which is caused by connecting the sound system to any portable generator or inverter.
7. Repair of damage which is caused by using any other connection or hookup which is stated in this manual to be improper and likely to cause damage to the sound system.
8. Replacement of any unit which has been modified or altered in any way, by adding inputs or outputs, by permanently changing its appearance by painting, engraving in an exposed spot, etc.
9. Payments of any transit charges, freight, insurance, customs charges or brokerage fees, which may be incurred in providing warranty service involving international customers. Any such charges, if advanced by Hilton Audio Products, will be invoiced to the owner of the equipment.
10. Hilton Audio Products assumes no responsibility for any special, incidental or consequential damage.

## TOP DECK

### TONE ARM:

The cartridge and needle in the AC-500 are separate units. The needle used is a .7 mil diamond. Needles for this cartridge are easily obtained and replaced. The replacement needle number is a Pfanstiehl 793-D7, or an equivalent.

To replace the needle - separate the front edge of the red or grey needle from the black cartridge by inserting your fingernail in the front of the assembly. Pull downward and away from the head. To install - insert the back edge of the needle assembly into the cartridge first and pivot the front into place. After installing, inspect the needle to make sure it is positioned in the center of the rubber saddle. Avoid flicking dust from the needle with your finger, as this may dislodge the needle and will effect the sound quality. Remove any accumulated dust with a soft brush or needle cleaning pad.

If the cartridge should need to be replaced use the following procedure. Remove the turntable by lifting it out of the spindle well and set it aside. Turn the amplifier upside down onto a soft support, one that is high enough to allow the underneath side of the tone arm to be accessible. Remove the needle. The cartridge is held in place by a spring clip. Press down on the clip extension, located at the front edge of the cartridge, releasing the cartridge so it may be lifted out. Being very careful, disconnect the wires from the small connectors at the back end of the cartridge. Reinstall by reversing this procedure.

The counter weight is set to tracking pressure of 7 grams. This stylus is heavier than that of a home stereo turntable to insure against needle skipping when working on temporary stages or rickety tables. To decrease this tracking pressure will increase the risk of needle skipping, without appreciably lengthening the life of either needle or records.

For carrying, the tone arm must be locked in its clip.

### TURNTABLE AND DRIVE MECHANISM:

The foam pad on the platter is slightly less in diameter than a 7" record, so that records are easy to remove. The platter spins on a ball bearing which is secured in the bottom of the shaft well, and is almost free of friction.

The motor is a hysteresis-synchronous gearmotor. It is unaffected by voltage fluctuations and will hold speed at very low voltage. The motor drives the platter directly, with a drive wheel which has a soft rubber rim, and speed change is accomplished by moving the entire motor assembly towards or away from the center of the platter. Speed is infinitely variable from 27 to 60 RPM. When the speed control knob is in the OFF position, the drive wheel is disengaged from the underside of the platter, the motor is shut off, and the strobe light is turned off. This knob should be placed in the OFF position for carrying, or when the system is being used, without the turntable, for only voice reproduction or for tape playback.

The speed control is calibrated for 60 cycle current, unless 50 cycle calibration is ordered.

### STROBE:

A neon-lighted strobe is provided; the inner row of dots indicates 45 RPM, and the outer row 33 RPM. The two rows of lines or bars are for use with 50 Hz current. The bulb is a neon, No. NE-51H or B2A. It has a bayonet base; to remove it push in on the bulb, turn it to the left (counterclockwise) and it will popout. Unplug the power cord before removing the bulb.

The strobe light is turned off when the speed control knob in the OFF position.

### RECORD RESET MECHANISM:

Immediately to the right of the tone arm is the record reset mechanism. When the Hilton remote volume control/record reset assembly is plugged into either of the front edge panel RESET jacks, the button at the base of the microphone may be used to lift the tone arm and return it to any point on the record which you have previously selected.

To use the record reset for square dance calling: When a patter record runs out before your tip is finished, press and release the button at the base of the microphone. The arm will be lifted, the needle set back and lowered to the record faster and more smoothly than you can reset manually. If you depress and hold the button, the arm will be lifted and moved back, but will not be set down on the record until you release it. This allows you to stop the music for a talk-thru spot and restart it immediately when you wish to do so. The switch immediately in front of the reset mechanism deactivates it. When playing 12" LP records the reset should be switched off, so that if the button is accidentally touched,

the arm lift will not come up under the record and possibly damage it. If you have a guest caller or round dance leader who is unfamiliar with the equipment, you may wish to turn off the reset so that he or she will not accidentally restart the record at the wrong time.

To use the record reset in round dance teaching: The record reset is a very handy aid in round dance teaching. First, you can stop the music at any time, without having to pick up the tone arm manually. Second, if you determine ahead of time the adjustment necessary to restart the record in the pickup grooves, you can note that setting on the record label; then at class, you can restart that record at will with the remote button. Third, if a dance has a difficult passage which requires repetition, you can repeat the passage as many times as you wish. Locate the spot on the record and jot down the number of that setting. For instance, part B of a dance can be repeated as many times as you wish, without having to play the entire record up to that point. If you know ahead of time the proper settings that you need, you can at will, with the turn of a knob, start a record at any spot you wish, without having to hunt for it.

Adjusting the reset mechanism:

Adjustments are made with the set right side up and the platter in place. On the right side of the set there is a 1 inch opening with access to three screwdriver adjustments. The top left sets the low or rest point. The bottom center sets the high or up point. The top right is a factory set adjustment of the cycle speed, this should be the last adjustment made and then only if needed.

Set the lifter arm stop point so that the arm would drop in the leading groove of a record.

Place the tone arm on its rest and turn the set and the lifter on. Adjust the low (top left) so that the lifter arm is just above the top deck. Press and hold the reset button and adjust the high adj (lower) so the needle is about 1/8 inch off the record. Release the reset button and reset the low point. The low and high adjustments interact slightly and you must work back and forth a couple of times.

Refining the adjustments:

Most callers never reset to the start of the record. You may place the stop to the point you are going to use for your records and reset the high point. This will result in a lower setting off the record and a softer needle drop. However it will have to be reset if the stop is moved.

If necessary the speed may be adjusted to your desires. If the tone-arm bounces when lifted from the center of the record, the speed is TOO FAST. If the high point is correct and the needle slides across the record the speed is TOO SLOW.

#### SPEAKER DISCONNECT: Indicator Light

The Speaker Disconnect indicator light comes on if your system has over-heated. Over-heating can be caused by many things: a shorted speaker wire, a shorted speaker, or improper multi-speaker hookup. These are the most common causes of over-heating. After a minute or two the internal thermal circuit breaker will reset itself and the speakers will be reconnected. Unless the problem that caused the over-heating is corrected the thermal circuit breaker will continue tripping and disconnecting the speakers.

Both the Main and Monitor channel speaker connections are disconnected when the system over-heats.

You will notice that each time you turn on and off your AC-500 the Speaker Disconnect light comes on for a short period of time. This is normal and indicates all is working properly.

### FRONT PANEL

#### TWIN LED OUTPUT LEVEL METERS:

These meters are easy to see from a distance. One measures music, the other voice; and you can tell at a glance whether you have the proper balance between them. If the readings are equal or nearly so, your voice will be buried in the music and the dancers will have difficulty in hearing your commands. As a rule the reading for voice should be at least three LED lights above that of the music; in some halls this difference will need to be increased. If you must locate speakers so that you can not hear the voice-music balance yourself, have someone check it for you and tell when it is correct; then note the meter readings and you can maintain proper balance.

When the volume mode switch is moved from **NORMAL** to **INCREASED**, the meters remain on scale, and you can read voice-music balance at high drive levels as easily as at low levels.

### PHONOGRAPH SECTION:

The phonograph volume control adjusts the loudness of the music program for the main channel, when playing a record or playing back a tape or CD through the AUXILIARY MUSIC inputs. With the Main/Monitor switch in COMBINED position, it also controls the volume of the music program for the monitor channel. Adjustment of phono volume can also be done by using the Hilton remote volume control assembly in conjunction with the phono volume control.

PHONOGRAPH BASS AND TREBLE controls: Adjust the bass and treble compensation for the music program; this affects both the main and monitor channels. They have no effect on the voice program for either channel. Very wide latitude is provided, and we recommend using only the minimum adjustment from normal which will give you the music sound that you desire. For very worn, scratchy records, turning the treble control about 45 degrees to the left will filter out a large portion of the surface noise. See also the section titled GETTING THE MOST FROM YOUR HILTON.

### MONITOR SECTION

#### MONITOR VOICE AND MUSIC VOLUME CONTROLS:

These control the music and voice volume for the monitor channel only. If you use a monitor speaker, you can use these controls to give yourself as much music and voice volume as you wish, without affecting the volume or balance going to the floor through the main channel. The separate sets of controls make it possible, in the unlikely event of a failure in the main channel, to connect speakers to the monitor channel, shut off the main channel and complete your dance using only the monitor channel! The monitor channel has exactly the same power as the main channel.

Both Music and Voice Monitor Volume controls are disconnected when the MAIN/MONITOR switch is in the COMBINED setting. See the description of the MAIN/MONITOR switch in the Front Edge Panel area for a full description of how this switch is to be used.

#### MICROPHONE SECTIONS 1 & 2

Two identical high impedance microphone inputs are provided. Volume and bass-treble controls are completely independent of each other, and of the music program. You may use either input that you choose, with one exception: to use the EQ jack, you must use the no. 1 microphone input.

MICROPHONE TREBLE-BASE CONTROLS: One of the features which makes the Hilton sound systems outstanding is the ability of their voice circuits to reproduce cleanly the high frequencies which are absolutely essential for voice clarity and understandability of commands. If you have a voice in the bass range, turn the tone control to the right far enough to be sure that there is no boomingness; if you are a baritone, leave it near the normal setting. Even if your voice is high in pitch, do not turn the tone control more than 30 to 40 degrees to the left of normal. If you have not worked with Hilton equipment before, do not make the mistake of tuning out the highs in the voice to make the Hilton amplifier sound perhaps more like the sound of your voice on your previous sound system. To do so would be similar to buying a new color television receiver, and then tuning it so that the picture is black and white!

#### AUX. MUSIC:

These three controls are used to feed signals into and out of the PHONOGRAPH section of the AC-500's preamp.

Examples of signal input sources would be Tape Recorders, CD's, and Mini-Disk's. The controls marked A and B INPUT LEVEL are input controls. These two controls are fed by the 1/8" stereo jacks marked INPUT A and INPUT B on the Front Edge of the AC-500. The A and B INPUT LEVEL control sets the volume feeding the PHONOGRAPH section.

The OUTPUT LEVEL control adjusts the signal strength being feed to the OUTPUT jack on the Front Edge of the AC-500. This would be whatever signal is playing through the AC-500's PHONOGRAPH section.

See the section of this manual titled; MAKING TAPE RECORDINGS and PLAYING TAPE RECORDINGS, CD's, & ?, for more details on proper use of these three controls.

#### AUX. VOICE:

These two controls are used to feed signals into and out of the MICROPHONE section of the AC-500's preamp.

The OUTPUT LEVEL control adjusts the volume feeding the OUTPUT jack on the Front Edge Panel.

Both

MICROPHONE's 1 & 2 are connected through the OUTPUT LEVEL control to the OUTPUT jack. Examples of uses for this; to feed a Sound Enhancement system transmitter, and Voice only recording.

The INPUT LEVEL control adjusts the volume of the signal being played into the INPUT jack on the Front Edge Panel. This signal is feed to MICROPHONE 1 only! An example of using this input would be a voice only track on a stereo tape recording. It is generally preferable to play music through the PHONOGRAPH section but you can use this input for music and/or voice playback.

#### POWER:

This red light comes on as soon as AC power switch is turned ON.

### FRONT EDGE PANEL

#### AUXILIARY MUSIC:

Two 1/8" stereo jacks and a gold RCA type jack are provided for feeding signals into and out of the MUSIC section of the AC-500.

AUX 1 and AUX 2 jacks are used to feed signals into the system. The front panel controls marked AUX 1 LEVEL and AUX 2 LEVEL adjusts the signal level from these two jacks before the signal reaches the MUSIC section. The two tracks of a stereo or two track recording will be combined when connected to these AUX jacks.

The OUTPUT jack is an adjustable output level of whatever signal is PLAYING through the MUSIC section. The volume is set using the OUTPUT LEVEL control on the Front Panel. See the section MAKING TAPE RECORDINGS for more details on using this jack.

#### EQUALIZER JACK:

The AC-500 is equipped with a 1/4" stereo jack on the Front Edge Panel marked EQ MUSIC. This jack opens up the circuit between the preamp and the power amplifier and allows the insertion of an external equalizer to provide extremely wide tone control in the music circuit. Any high quality stereo equalizer may be used, and we make no recommendations as to make or model. The Pitch Shifter, the DEP-2000, is also connected through the EQ MUSIC jack.

A special cord is required to allow you to connect the AC-500 to an equalizer. Plug this cord into the EQ MUSIC jack on the front panel. Connect the plug marked EQ IN to the left channel input of the equalizer. Connect the plug marked EQ OUT to the left channel output of the equalizer. Turn the EQ switch to "ON".

Set all equalizer controls at 0 (mid range). Set all tone controls on the AC-500 at normal, pointers straight up. Play some music and you will find that by adjusting the various controls on the equalizer you can vary the tonal quality of the music.

#### REMOTE CONTROL JACKS:

By plugging in the Hilton remote volume control assembly into Mic 1 REMOTE, the music volume can be adjusted with the knob at the microphone, without touching the knob on the front panel. A second REMOTE jack is provided in the Mic 2 section. **IF ONLY ONE REMOTE IS CONNECTED IT MUST BE CONNECTED TO MICROPHONE 1!** The REMOTE jack located in Mic 2 will only work with a Remote simultaneously being used into Mic 1. When two remote cords are being used one needs to be turned all the way down so the other has the full range to work with. If both are up all the way neither will have any control of the music.

Recommended operation: Plug in the remote control and turn its volume full on. Set the phono volume control at a level slightly higher than you need for best voice-music balance. With the remote control, decrease the music level so that your voice comes out clearly over the music. Without touching the amplifier knob you can now either drop the music volume to 10% of its present level or increase it for added excitement and lift for sing along choruses. The remote will not turn the music totally off. If you do not want any music - use the Record Reset!

#### RESET JACKS:

Plug in the proper plug of the Hilton remote volume control/record reset assembly to operate the record reset with the button at the base of the microphone. A second RESET jack is provided - both can be used independently or together.

#### VOLUME MODE:

The two position VOLUME MODE switch makes operation and control easy and convenient no matter how large or small the dance.

The NORMAL setting should be used in all general situations. Much like the low gear setting on your car, the NORMAL setting allows you to use this powerful sound system with even a small group and still have easy control of the volume.

In the INCREASED setting the volume is greatly increased at any given knob setting on the volume controls. When floor coverage requires settings higher than 11 o'clock in the NORMAL setting, switch to the INCREASED setting. Due to the dramatic increase in power be certain to decrease your volume knob settings before changing this setting.

#### MAIN/MONITOR:

This two position switch allows you to lock the main and monitor channels together, making their combined output available for floor coverage.

In the SEPARATE setting the MONITOR VOLUME section of the Front Panel control the music and voice going to the monitor power amplifier. A speaker plugged into one of the two Monitor Speaker connections on the REAR PANEL will be controlled by these two volume controls.

In the COMBINED setting, both music and voice for both channels are controlled by the knobs for the main channel. The monitor knobs are inoperative in this setting. All four speaker outlets on the rear panel will produce sound at identical volume. With this setting, you will not have a caller's monitor, but you do have all the power of the AC-500 available for floor coverage. **DO NOT CONNECT MORE THAN TWO SPEAKERS TO EITHER CHANNEL WITHOUT READING AND CAREFULLY FOLLOWING THE INSTRUCTIONS AND DIAGRAMS IN THE SECTION ON SPEAKER HOOKUP.**

#### AUX. VOICE:

A 1/8" stereo and gold RCA type jack are provided for feeding signals into and out of the VOICE section of the AC-500.

The jack marked INPUT is used to feed signals into the MICROPHONE 1 section of the AC-500's preamp. The Front Panel control marked INPUT LEVEL adjusts the signal volume from this jack before the signal reaches MICROPHONE 1's volume and tone control. An example of using this jack is: Playing the voice only track of a stereo recording into the AC-500.

See the section PLAYING TAPE RECORDINGS, CD's, & ? THROUGH YOUR AC-500 for more details on using this jack.

The OUTPUT jack is an adjustable output level of whatever signal is PLAYING through the MICROPHONE 1 and MICROPHONE 2 sections. The volume is set using the OUTPUT LEVEL control on the Front Panel. Two examples of using this jack are: Making a stereo recording where you want the voice only on one track; Connecting the two Microphone circuits into a Sound Enhancement (also known as Assistive Listening Systems) transmitter.

See the section MAKING TAPE RECORDINGS for more details on using this jack.



## REAR PANEL

### SPEAKER OUTPUT JACKS:

A total of four speaker jacks are located on the rear of the AC-500 - 2 for the Main circuit and 2 for the Monitor circuit. These jacks are controlled by the corresponding knobs on the Front Panel except; when the MAIN/MONITOR switch is in the COMBINED position, all four speaker outputs are controlled by the main channel controls.

The speaker outputs are mono 1/4" phone jacks, compatible with standard mono 1/4" phone plugs. The main channel jacks are connected in parallel with each other, as are the monitor jacks. Optimum impedance load is 4 to 16 ohms. Do not connect any combination of speakers which produces a net impedance load of less than 4-ohms. Two series Y connectors are furnished with the AC-500, for use in connecting more than two speakers to the same channel. See the section titled SPEAKER HOOKUP for detailed instructions for hookup of multiple speakers.

Do not connect a tape recorder or any other sound equipment to the speaker jacks of the AC-500. Doing so could cause overheating of the amplifier, and possibly damage it.

### SIGNAL OUT:

Two gold RCA jacks are provided one marked HIGH and the other LOW. Both jacks are feed by the Main channel and will vary in volume with the setting of the Main channel volume and tone controls.

The HIGH jack is a variable line level signal (sometimes referred to as an auxiliary level). It is used to feed a line level signal to an exterior system.

The LOW jack is a variable microphone level signal. It is used to feed a microphone level signal to an exterior system.

These two jacks may be used for making monaural tape recordings from the AC-500, or to connect a slave amplifier, to gain even more power and coverage. When using these outputs remember they are dependent on the volume and tone setting of the Main channel controls.

See the sections titled MAKING TAPE RECORDINGS and CORRECT HOOKUP FOR A SLAVE AMPLIFIER.

Units which have been damaged by connecting to a wrong power source will not be covered by the warranty.

### POWER ENTRY MODULE:

The power entry module contains the power off/on switch, fuse holder, voltage selector and power cord receptacle.

To open the power entry module to replace the fuse or change voltage use a small screwdriver, ball point pen or similar device. Remove the power cord, insert tip of tool at a 45 degree angle into notch between the power cord receptacle and power module cover, apply pressure towards cover while prying outward.

To change the fuse: the fuse holder is attached to the cover and the fuse is easily removed and replaced. Recommended fuses for North American 120V operation: 1 MDQ5, (5 amp, 250V), for European 220V operation: 2 GDC2.5, (2.5 amps, 250V), one for each power leg. If the fuse again blows almost immediately, unplug the amplifier and do not attempt to use it until the cause of the problem has been determined. Refer to the trouble shooting section of this manual.

To Change Selected Voltage: Four AC voltages can be used with the AC-500: 100V, 120V, 220V, and 240V. To change between voltages, pull the voltage selector card straight out of the housing using the indicator pin. Orient the selector card so that the desired voltage is readable at the bottom of the card. Orient indicator pin to point up when desired voltage is readable at the bottom. Insert voltage selector card into the housing with edge showing selected voltage entering first and printed side of card facing the fuse compartment. Reinstall cover and verify the indicator pin shows the desired voltage.

## Voltage Selector Card Orientation

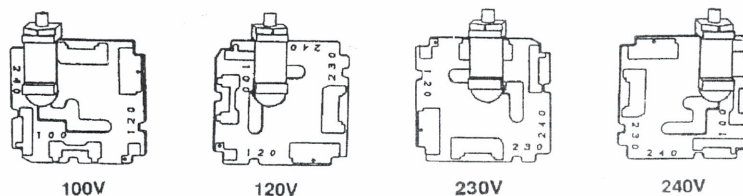

If required, the fuse holder may be changed to take either a single North American fuse or two European standard fuses. To change, remove the Phillips head screw holding the fuse holder to the cover, turn the holder over and reinstall with the screw. The European arrangement requires two fuses.

### AUXILIARY AC OUTLET:

A two prong switched auxiliary AC socket is provided. This outlet is switched off/on by the power switch in the POWER ENTRY MODULE. It is meant to be used for low wattage external devices such as; a wireless microphone, tape recorder, or CD player. The circuit does go through the main fuse in the POWER ENTRY MODULE.

## SETUP AND OPERATION

Turn all volume controls off, power switch off, set the tone controls at normal. Set up your speaker or speakers, locating them above the heads of the dancers and positioning them so that their cones of sound cover all area of the floor. Connect them to the amplifier, following the instructions given in the section titled SPEAKER HOOKUP. Plug in your microphone.

Check to be sure that the power source is the correct voltage. Plug in the power cord, and turn the system on. Start the turntable and see that it strobos correctly. Turn on the microphone and test by speaking into it--not by blowing into it. Put on a record and check music volume and tone controls. Check the record reset to make sure that it is turned on, and that it is adjusted to reset the needle where you want it on the record. In a strange hall, put on a called record and walk the floor to make sure that your speakers are properly located to cover the entire floor with a comfortable level of sound.

If you use a monitor, always start calling to each record with the monitor volume shut off, until you have made sure that the total volume and voice-music balance are properly set for the comfort of the dancers; then turn up as much monitor volume as you want. For more information about operation, see the section titled GETTING THE MOST FROM YOUR HILTON.

### SPEAKER HOOKUP

The minimum impedance load for each channel of the AC-500 is 4 ohms.

Depending upon the size, shape, and acoustic characteristics of a hall, getting comfortable sound coverage may require one, two or more speakers. It is important to locate them properly, for best coverage of all areas of the floor. For information on locating speakers in the hall, see the heading SPEAKER LOCATION in the section titled GETTING THE MOST FROM YOUR HILTON.

It is also very important to connect them properly, to the amplifier and to each other, to get the best performance from the amplifier and from the speakers.

In multiple speaker hookup, it is necessary to consider impedance. This is the electrical resistance of the voice coils of the speakers. The lower the impedance, the more electrical energy is applied to the speakers. This is why specifications on power amplifiers will show a given power rating into an 8-ohm load, and a higher power output into a 4-ohm load.

If a loudspeaker were 100% efficient, all of the electrical energy delivered to it by the amplifier would be converted into

sound energy. Unfortunately, speakers are not 100% efficient; in fact even the highest quality speakers in the best designed enclosures are no more than 25% efficient. The electrical energy which is not converted to sound by a speaker is converted into another form of energy--heat. This heat must be dissipated at two points: the voice coil of the speaker, and at the amplifier. Excessive heat at either point can cause damage to the sound system.

Improper hookup can cause excessive heat dissipation, and this problem is compounded when less efficient speakers are used.

By carefully following the instructions in this manual for speaker hookup, you will maintain the best net impedance load for various speaker combinations. Improper hookup of speakers can cause embarrassing interruptions of your program, even if you are using Hilton speakers. Over-driving speakers with low power ratings or connecting them improperly can cause damage to the speakers, and in event of a shorted voice coil, possibly cause damage to your amplifier.

#### ONE HILTON HC-8 OR LB-1 SPEAKER

Plug directly into one of the speaker jacks. Impedance: 4-ohms.

#### ONE HILTON FOLDED HORN SPEAKER

Plug directly into one of the speaker jacks. Impedance: 8-ohms.

#### TWO HILTON HC-8 OR LB-1 SPEAKERS

Plug each speaker into a series Y, then plug the Y into one of the speaker jacks. Impedance: 8-ohms.

#### TWO HILTON FOLDED HORN SPEAKERS

Either plug both speakers into the amplifier or plug one speaker into the amplifier and connect the second speaker to the first speaker. Impedance: 4-ohms, either way.

#### MORE THAN TWO HILTON FOLDED HORN SPEAKERS

DO NOT CONNECT MORE THAN TWO SPEAKERS TO THE SAME CHANNEL WITHOUT CAREFULLY READING THE INSTRUCTIONS WHICH FOLLOW, AND THE DIAGRAMS CONTAINED IN THIS MANUAL.

The minimum impedance load for the AC-500 amplifier is 4-ohms, for best operating results. Hilton folded horn speakers are 8-ohms and the LB-1 and HC-8 are 4-ohms. Two Hilton folded horn speakers connected direct to one channel produces a 4-ohm load. If you should connect four Hilton folded horn or two HC-8 speakers directly to the same channel, this parallel connection produces a 2 ohm load, which at high drive levels will produce excessive energy which is dissipated in the form of heat.

The hookup diagrams in this manual show correct use of the series Y connectors for hookup of 3, 4, 6, and 8 speakers, to obtain equal volume level from each speaker and maintain proper net impedance. If it should be necessary to connect 5 or 7 speakers, a slave amplifier should be used. It is impossible to get equal volume from these combinations with a single amplifier, unless you connect all of them in series; this hookup is not recommended.

If you must use a speaker hookup not shown in these diagrams, or if you plan multiple hookup of speakers not manufactured by Hilton, the following points must be considered:

1. You must use a hookup which will produce a net impedance load of 4-ohms or higher to one amplifier channel.
2. The net impedance to each leg of a series Y connector should be the same, or the speakers driven by one leg will receive more energy and therefore produce more volume than those driven by the other leg.
3. Different makes and types of speakers have different degrees of efficiency and will produce different sound volumes when driven at the same amplifier output level. Mixing different types of speakers is not recommended, but if you must do so, use the more efficient speakers nearest the center to cover the main portion of the floor, and the less efficient ones at the ends to cover the two front corners of the floor.

#### HOW TO DETERMINE NET IMPEDANCE

To determine the net impedance of a given combination of speakers, it is necessary to understand and apply the

following:

IMPEDANCE: The resistance produced by the voice coil of a speaker, expressed in ohms. Hilton folded horn speakers are 8-ohms, the HC-8 and LB-1 are 4-ohms; other makes have varying impedances, usually from 4 to 16 ohms.

PARALLEL CONNECTION: A hookup in which the output of the amplifier is divided among speakers, with part of the output going to each speaker. The speaker jacks on your main channel are connected in parallel, as are those of the monitor channel. The jacks on top of the Hilton folded horn speaker are also connected in parallel with each other.

SERIES CONNECTION: A hookup in which all of the amplifier output passes through each speaker in turn, instead of being divided up among them. If you plug a series Y connector into the amplifier and connect one speaker to each leg, you have the speakers connected in series.

SERIES-PARALLEL CONNECTION: If you have two groups of speakers which are connected in parallel within the group, and connect one group to each leg of a series Y connector, you have a series-parallel connection.

NET IMPEDANCE--The combined impedance of all speakers in a hookup:

(Each speaker must be the same impedance)

IN PARALLEL--the impedance of 1 speaker, divided by the number of speakers in the parallel hookup.

IN SERIES--the impedance of 1 speaker, multiplied by the number of speakers in the series hookup.

IN SERIES-PARALLEL--the net impedance of each parallel group, multiplied by the number of parallel groups connected in series.

#### CONNECTING SPEAKERS OTHER THAN HILTON SPEAKERS

Any one speaker with the impedance of 4-ohms or higher can be connected directly to the AC-500.

Before connecting two speakers to the same channel, first find out their impedance, if possible. If they are 8-ohms or higher, use the same hookups as for Hilton speakers. Two 4-ohm speakers must be connected in series. For other combinations, follow the instructions given above to obtain a net impedance of no less than 4-ohms.

CHECK THE POWER RATING OF THE SPEAKER AND BE CAREFUL NOT TO EXCEED IT. Over driving of a speaker with a low power rating can result in any of the following: 1. Distortion of the program. 2. Voice coil may become jammed at one end of its excursion, making the speaker inoperative. 3. A short circuit may occur in the voice coil, ruining the speaker and possibly causing damage to your amplifier.

#### NEVER CONNECT TWO AMPLIFIERS TO THE SAME SPEAKER OR SPEAKERS

We have been in situations in which a caller working from the stage and a round dance leader working from the floor share the program. The caller has his amplifier on a table on the stage; the round dance leader's amplifier is set on the stage where it is accessible from the floor. Both of them want to use the same set of speakers. This is very risky arrangement. If while shifting back and forth, both amplifiers are connected to the same speaker, at least one amplifier will likely be damaged.

In such a situation, to prevent damage, each amplifier must have its own speaker system, or a positive switching system must be used, to make it impossible for more than one amplifier to be connected to a speaker at the same time. Any damage which is caused by this kind of improper hookup is not covered under warranty.

If you ever do find it necessary to work with this type of hookup, we can make up a connector box for you which will allow you to switch from one amplifier to another, but also make it impossible for both to be connected at the same time.

## GETTING THE MOST FROM YOUR HILTON, AND AVOIDING DAMAGE TO IT

### MICROPHONE TECHNIQUE

Always work close to your microphone -- never let it get more than an inch from your lips. Work straight into it, as much as possible. Holding the microphone too far from your lips, or speaking across it rather than into it, can rob you of more than half the power and efficiency which is built into your Hilton. If you hold your microphone two inches from your lips, it won't pick up half as much sound as at one inch--it will pick up only one-fourth as much. If you then try to turn up four times as much gain in an attempt to be heard, you will be fighting feedback.

### FEEDBACK

The feedback squeal can occur at any time that power is turned up on an amplifier and an open microphone is near a loudspeaker. The more power is turned up, or the closer the microphone is to the speaker, the more likely feedback will occur. The squeal is caused by sound from the speaker being picked up by the microphone and fed back into the amplifier. It is almost always the result of bad microphone technique, working so far from the microphone that you have to turn up an excess of power in order to cover the floor. It can also be caused by standing too close to a speaker. Only very rarely is feedback caused by any defect in the sound system.

### VOICE-MUSIC BALANCE

For the dancers to hear and understand your commands, your voice must come out clearly over the music. Never turn up so much music that your commands cannot be heard clearly. Often, when a caller's voice is buried in the music, dancers may ask for more voice. If the voice program is loud enough to be heard all over the hall, what is really required is not more voice, but less music. As a general rule, the larger the hall, or the more reverberant, the more the voice must stand out over the music in order for the dancers to hear. If you can't judge the proper balance yourself, get someone you can trust out on the floor, to help you get the proper volume and voice-music balance for that particular hall. If you can't become accustomed to working with the proper balance and feel that you need more music, don't turn up the music volume out on the floor. Plug in a monitor speaker and turn up as much music as you need to be comfortable.

### SPEAKER LOCATION

Speakers should be placed so that the entire floor is covered with sound. They must be high enough so that when the sound level is comfortable at the rear of the hall, it is not deafening to the dancers at the front. Speakers should be elevated and aimed at the dancers at the rear of the hall, so the most intense part of the beam of sound passes over the heads of the dancers at the front. You should set up so that you can get close enough to a speaker to be able to hear the voice-music balance, but not so close that you are continually fighting feedback. Try never to aim a speaker directly at a hard, flat, painted or panelled wall, which will cause echo and bounce-back of sound. If you must direct speakers towards such a surface, tilt them downward, so that the beam of sound is aimed at dancers, not at the wall. Wherever it is practicable, direct speakers towards an absorbent surface--one which is draped or acoustically treated.

### USING YOUR TONE CONTROLS

In a hall which is excellent acoustically, you can set your tone controls, within limits, almost any way you choose, to get the sound quality of voice and music that you prefer.

But in a hall which is reverberant, not only must the voice-music balance be adjusted to compensate for the acoustic conditions, but the tone controls for both music and voice must also be adjusted. In a reverberant hall, not only must you cut the music volume down, but you should also use your tone controls to remove excess bass boominess from the music, and take out some of the highs in the music, which would interfere with the highs in the caller's voice. Adding more treble with the microphone tone control will help in making the voice stand out over the music. In a hall with a lot of echo, the object is to get as much intelligibility into the program as possible, even at the sacrifice of pleasing overall sound quality. Even if the overall effect is not what you would prefer to hear, if the dancers can understand it is possible for them to dance.

### REVERBERATION TIME

To determine the reverberation time of a hall, stand in the center of the empty hall, clap your hands, and carefully count the number of seconds before the sound dies away completely. 1 second or less: excellent acoustic conditions. 2 to 2-1/2 seconds: not good, but with speakers placed properly and careful attention to voice-music balance and tone compensation, it is possible to get fairly good sound, with good intelligibility. 3 seconds or more: the sound will not be good, no matter what equipment you use or how well you operate it. Only acoustic treatment of such a hall will produce sound which is adequate for square dancing.

### NEEDLE CARE

Your needle should with proper care last hundreds of hours. Be careful not to drop it on the record or on any metal surface, or to drag it across the surface of the record. Be sure that the tone arm is locked firmly in place before securing the amplifier.

### HANDLING AND TRANSPORTING

Your Hilton is designed for ruggedness, and with the normal handling to be expected in portable use, it will give you years of trouble-free service. By using the protective carrying cartons furnished with each Hilton sound system, you may stow components in any position for hauling, as long as they are protected from being bumped or banged around.

### MAKING TAPE RECORDINGS

There are many types and brands of cassette recorders on the market, ranging from very compact and inexpensive, up to premium quality models with quite sophisticated features. Even within the same price range, one model may have different characteristics from another, and the same hookup which produces good results with one recorder may not do so with another. Therefore, it may require a bit of experimenting to arrive at the hookup and adjustments which gives the best results with a given cassette recorder.

### CAUTION

Do not allow anyone to connect a tape recorder directly to the speaker socket, to the series Y connector, or to any socket on a speaker. Some recorders have inputs of such low impedance that if they are connected in a speaker circuit they produce the same effect as a improper speaker hookup; Overheating and possible damage to the AC-500 could result.

### MONAURAL CASSETTE RECORDINGS

Use the SIGNAL OUT jacks on the Rear Panel to make Monaural recordings with full program (the same as is going to the speaker). The HIGH jack is an adjustable line level signal and would be connected to the Line or Auxiliary input of your recorder. The LOW jack is an adjustable microphone level signal and would be connected to the Microphone input of your recorder. The signal strength at these two jacks is dependent on where the Main channel volume (and tone) controls are set. If you have a choice of using either one with your recorder we suggest you make short test recordings both ways to find which one works best with your recorder.

The better the quality of your cassette recorder, the better the quality of your recordings will be. If you have one of the better units, in the medium or higher price range, and you use its automatic recording level control (ARL or ALC) it will record with a wide range of input signal strength, but during pauses with no signal, there may be annoying hash or background noise. Some of these units also have a manual adjustment for recording level, therefore we recommend using the manual control to avoid this noise problem.

Another way to make monaural recordings is by the use of a telephone pickup (also referred to as "inductive pickup's"). These are available at many outlets--Radio Shack, for instance. To use one of these pickups, loop your speaker cord around it and secure it snugly with a rubber band. Plug the other end of the cord into the microphone input on the recorder. With some cassette recorders, this produces better results than a direct hookup. No matter what recorder is used, no damage can be caused, because there is no direct contact with your sound system; the pickup is made through the insulation on the speaker cord. One other advantage is multiple recorders can be connected. (The speaker cord must be connected to a speaker, or no signal will be produced.)

### MAKING TWO TRACK RECORDINGS

On the Front Edge Panel are two gold RCA jacks marked OUTPUT. One is located on the left side in the AUXILIARY MUSIC area and provides a signal out from the Phonograph section. The other jack is located on the right side in the AUX. VOICE area and provides a signal out from both Microphone's. The signal strength out of these jacks is controlled by the OUTPUT LEVEL control above each on the Front Panel. Neither of these outputs are affected by the volume and tone controls of the AC-500's preamp.

These jacks may be connected to a stereo recorder to make recordings with voice on one track and music on the other track. If your recorder has a record level meter use it to gage how high to set the OUTPUT LEVEL controls. As with Monaural recordings it is advisable to make short test tapes to determine the best level to adjust the OUTPUT LEVEL control to. Again the quality of the recordings will depend upon the quality of the recording equipment; but with a good stereo deck you can make recordings of excellent quality.

In general, too much background noise indicates the OUTPUT LEVEL is set to low. Distortion of the recording indicates too high a level. Because Automatic Recording Level controls (ARL or ALC) increase the record level during quiet and low signal level periods, recordings made this way tend to have annoying hash or background noise. For this reason we recommend using the manual adjustment recording level if your recorder has this capability.

### PLAYING BACK TAPE RECORDINGS, CD's, & ?

Why, you may ask, the ? in the above title? New products are coming out all the time in the audio industry. At the time this manual was being written Sony had recently introduced their Mini-Disk system. It is likely that other new systems are on the drawing boards or in the minds of engineers that we could not even guess at. Because of this the AC-500 was designed with enough flexibility that all current, as well as future, designs will work with your AC-500!

We can make the last statement with confidence because of the design flexibility of the playback circuit in the AC-500. That being said, we must also point out that having this amount of flexibility requires a greater understanding of how to use it on your, the owners, part.

**CAUTION: Do not use the two microphone inputs for tape playback.**

First lets go over some general rules for playing back through the AC-500. Latter in this section we will get into specifics on connecting particle types of devices to the AC-500.

Before connecting the tape recorder, CD, or ? do the following to the AC-500. Set the MUSIC VOLUME control at or below nine o'clock and the MUSIC BASS and TREBLE controls at normal. Set the MUSIC AUX. 1 and AUX. 2 LEVEL controls at midway position. If you will be playing back through the microphone circuitry set the MICROPHONE 1 and AUX. VOICE INPUT LEVEL controls like the MUSIC section. Once connected, turn up only enough volume on the tape recorder to get a soft listening level, the same as, or slightly less than, a record with the same music or microphone volume settings. Now adjust the MUSIC VOLUME, BASS and TREBLE controls on the AC-500 to get the sound level and quality that you want. Do the same with the MICROPHONE 1 circuit if you are using it. Many tape recorders are a bit lacking in brilliance on playback through an amplifier, and you may wish to decrease bass and increase the treble to get the tone quality that you want.

Use caution in setting the AUX. LEVEL controls and output volume control on your recorder. Setting either too high can result in distortion, especially during peaks in the music program. Keep in mind that you are using the AUX. LEVEL controls and output control on the recorder to set the proper signal level going into the AC-500, not as volume controls. Once these are set, use the MUSIC and MICROPHONE 1 volume controls to adjust the volume.

#### PLAYING BACK MONAURAL TAPES

Connect a shielded cord from the output of the tape recorder to either the AUX. 1 or AUX. 2 jacks on the Front Edge Panel. Set the music volume control at or below nine o'clock and the music bass and treble controls at normal. Set the AUX. 1 and 2 LEVEL controls at midway position. Turn up only enough volume on the tape recorder to get a soft listening level, the same as, or slightly less than, a record with the same phonograph volume setting. Now adjust the MUSIC VOLUME, BASS and TREBLE controls on the AC-500 to get the sound level and quality that you want. Many tape recorders are a bit lacking in brilliance on playback through an amplifier, and you may wish to decrease bass and increase the treble to get the tone quality that you want.

Use caution in setting the AUX. LEVELS and output volume control on your recorder. Setting either of these too high can result in distortion, especially on peaks in the music program.

#### PLAYING BACK TWO TRACK RECORDINGS

Connect a dual shielded cord from the output of the tape recorder, one cord to AUX. 1 or 2 and the other to AUX. VOICE INPUT on the Front Edge Panel. Set the music volume control at or below nine o'clock and the music bass and treble controls at normal. Set the AUX. MUSIC and VOICE LEVEL controls at midway position. Turn up only enough volume on the tape recorder to get a soft listening level, the same as, or slightly less than, a record with the same music volume setting. Now adjust the MUSIC VOLUME, BASS and TREBLE controls and the MICROPHONE 1 VOLUME and TONE controls on the AC-500 to get the sound level and quality that you want. Reverse the plugs into the AC-500 if the music and voice are not playing back in their respective channels. Many tape recorders are a bit lacking in brilliance on playback through an amplifier, and you may wish to decrease bass and increase the treble to get the tone quality that you want.

## CORRECT HOOKUP FOR A SLAVE AMPLIFIER

In certain situations it is desirable to use not one, but two or more amplifiers, each driving its own speakers, for proper sound coverage in halls which are too large to cover with one amplifier; to put sound in an additional room which requires a different sound level than the main hall; or to cover the small section of a "L" shaped hall which requires less volume than the main section of the floor, etc.

The gold RCA jack, SIGNAL OUT - LOW, on the Rear Panel can be used for feeding a signal to a slave amplifier. To connect a slave amplifier, use the following instructions.

Set up the main amplifier with its speakers to cover the area desired. Set up the slave amplifier with its speakers to cover its assigned area. If the slave amplifier is to be located no more than 30 feet maximum away from the main amplifier, plug a shielded cable from the SIGNAL OUT - LOW jack into a high impedance microphone input on the slave amplifier. SET THE TONE CONTROL FOR THIS MICROPHONE INPUT TO FULL BASS, ALL THE WAY COUNTERCLOCKWISE. Put a called record on the turntable of the main amplifier and turn up enough volume to cover its assigned floor area at a comfortable sound level. Then turn up the microphone volume on the slave amplifier to produce sound coverage of its assigned floor area at a comfortable level. No further adjustment of the slave amplifier will be necessary. Every change of volume, treble, or bass which is made on the main amplifier will be duplicated by the slave amplifier.

If the slave amplifier must be located more than 30 feet away from the main amplifier, the use of a plain shielded high impedance cable is not recommended, because of the noise that will be introduced into the system. In this case, you must use sufficient length of LOW IMPEDANCE cable, and a pair of LINE MATCHING TRANSFORMERS. An adapter plug will be required, one end being a male RCA, the other a female 1/4" phone plug. Plug one transformer into this adapter which is then plugged into the SIGNAL OUT - LOW jack on the main amplifier. Connect the cable and the other transformer. Plug the second transformer into the microphone input on the slave amplifier and proceed as described above.

Disconnecting a slave hookup: Before disconnecting, make sure that both the main and the slave amplifiers are turned off. If they are turned on and volume controls are turned up, unplugging will cause a loud pop in the speakers, and even possibly damage them.

Some installations require the use of more than one slave amplifier; in some cases speakers must be located at both sides or both ends of the hall. Please contact Hilton Audio Products for professional advice before attempting such installations.

## ROUTINE INSPECTION AND MAINTENANCE

Routine cleaning and inspection of your sound system, microphone and cords will help in preventing trouble and maintain the appearance and performance of your Hilton.

### PAINTED AND FINISHED SURFACES

Clean all of the painted and finished surfaces and knobs with a soft cloth or sponge dampened with a mild detergent solution. Do not use chemical cleaners or solvents as they may damage the paint and plastic knobs. A vacuum cleaner with a duster brush attachment does a good job cleaning dust and loose dirt from the top deck and panel of the amplifier.

### CHECKING AND CLEANING PHONOGRAPH NEEDLE

Always keep a spare needle, in case of damage to the one that you are using. To check your needle, put on a familiar record, and listen carefully to the music. Change to a new needle, again listen carefully for any change in the sound of the music. One symptom of a worn needle is a loss of highs in the music, making it sound bassy; this tells you that it is time to change needles. If dust accumulates on the needle around the cartridge, gently brush it off with the needle cleaner provided with your system.

The needle assembly is the gray (or orange) portion of the phonograph cartridge. To replace the needle, grasp the needle assembly and pull the front downward away from the head while pulling towards the front of the head. Reverse this procedure to install the new needle.

### TURNTABLE MAINTENANCE AND ADJUSTMENT



Any fluctuation of turntable speed is the result of slippage between the drive wheel and the underside of the turntable platter. This slippage may be caused by an accumulation of oily film on the underside of the platter and the rim of the drive wheel. Also the shaft and bearing may have become dry or gummed up, not allowing the platter to spin freely.

For routine maintenance, you should obtain a spray can of a non-lubricating cleaner, the type used for degreasing radio and TV tuner controls. Perform the following procedure about every six months or more often if the unit is heavily used.

Lift the platter straight up out of the shaft well. Dampen a cloth with the cleaner and thoroughly clean the underside of the platter inside the strobe dots, the platter shaft, and the rim of the drive wheel. Using a pipe cleaner or Q-Tip dampened with cleaner, clean the inside of the shaft well. Lubricate the shaft with a light film of Lubriplate or light machine oil. Reassemble the unit and check that the platter spins freely. If slippage was because of oil on the platter and drive wheel, this will correct the problem.

If after cleaning and lubricating the speed still does not hold constant, it is the result of incorrect pressure of the drive wheel on the underside of the platter. This pressure is controlled by a spring which exerts upward pressure on the motor mount. If the unit has been dropped or bumped, a change in the spring tension may have occurred.

To check the tension of this spring, with the turntable turning and set for 45 RPM, stall the platter with your finger. You should feel a resistance from the torque of the motor. When you remove your finger, the platter should reach normal speed in less than one revolution. If it does not, the spring tension is too weak and the drive wheel is slipping.

To adjust the spring tension, lift the platter out and locate the slotted adjusting screw, located about 1/4" from the rim of the drive wheel. Loosen the lock nut, and turn the screw counterclockwise to increase the spring tension, or clockwise to decrease the tension. Increase the spring tension no more than necessary. When the tension is correct, tighten the locknut and replace the platter.

#### CHECKING OF PLUGS, SOCKETS, AND CORDS

Cords, plugs, and sockets take more punishment than any other component of your sound system. For this reason, they should get extra attention, more frequent checkups, and extra care in handling and stowing to prevent failure in operation. Fortunately, there are advance warning signals before these components fail. If you know what to look for, you can avoid embarrassing failures at the dance.

To check your cords, set up your sound system, plug in your mic and put on a record. As you call, wiggle each plug in its socket and flex each cord along its length; do this for all mic and speaker cords. Listen for static and interruptions, which are warning signals of future trouble.

#### CHECKING THE MICROPHONE

Check your microphone from time to time-has its response changed? A mic whose diaphragm is starting to drag will lose its bass response and sound tinny, and there will be an increased susceptibility to feedback. Care of a microphone is fairly simple. Don't drop it, don't blow into it and don't spray or squirt anything into it in an attempt to clean it. Keep your microphone in a dry place when not in use. Excessive moisture inside the microphone can cause corrosion and oxidation resulting in unnatural sound or a complete microphone failure. While checking your microphone look for any screws that might have loosened on the mic itself or on the remotecord assembly. Carefully tighten any loose screws or nuts, replace any that are missing. Examine the microphone cable especially where the wires enter the plugs-look for frayed or bare wires and loose connections. With the microphone plugged into the amplifier and turned on, speak into the mic while moving the cable. Listen for crackling noises or intermittent operation indicating broken or loose wire/s. Microphone cables are constructed with shielded cable and like any wire will withstand only so many twist and bends before the wires will break. When storing your mic cord, coil the cord avoiding sharp bends-this will certainly extend the life of your microphone cord assembly.

#### CHECKING SPEAKERS

If a speaker has been dropped or handled roughly, it may develop a misalignment of the voice coil resulting in a "dragging cone". To check for this, hook up the speaker to the amplifier and put on a record. Turn the volume off, and set the bass at maximum and the treble at minimum. Put your ear close to the speaker and turn up the volume only enough to hear the music clearly. If the cone is dragging, you will hear a rasp on each bass note. The speaker may sound normal at your usual volume and tone setting, but over time the problem may become worse and will require replacing the speaker. While the speaker is connected set your tone controls for normal and turn up the volume while playing a

record. Listen for any rattles or vibrations caused by loose grill or trim. Tighten any screws as necessary.

Establishing a routine schedule of cleaning and examination of your sound equipment could very well keep you from having an equipment failure at a most important time. Whenever you setup or take down your equipment, keep your eyes open for signs of wear, corrosion, looseness, etc. and correct any of these problems as soon as possible. Your equipment serves you well and without it you're out of business-give it the care it deserves.

### IN CASE OF TROUBLE

Your Hilton was carefully assembled and tested before it was delivered to you. It is backed by our two-year warranty against failure of any component in normal use. Refer to page three for complete warranty information. If trouble should occur in the course of normal use and operation, which is not caused by accident or abuse, we will promptly honor the terms of our warranty, PROVIDED THAT YOU NOTIFY US BEFORE ATTEMPTING REPAIR. Upon such notification, we will make every effort to correct the problem, by having repair done locally if feasible, or by replacement of the defective unit at our expense, or by furnishing loaner equipment for your use while we do the necessary repair.

**NON WARRANTY REPAIR:** Even when your warranty is no longer effective, we advise that if a problem should develop, it would be wise to phone us before attempting repair. It is quite possible that we could save you time and money in helping you get your sound system back in operation.

#### BEFORE NOTIFYING US:

If any part of your Hilton sound system should develop a problem, the information that you give us should be as detailed as possible, in order for us to provide you the best and fastest service possible.

For example, if a microphone should stop working, the source of the trouble might be in the microphone itself, in the cord, or in the input of the amplifier. A few simple tests before notifying us would be of great value in isolating the source of the problem and correcting it quickly for you. Listed below are some tests that you could make in the event of trouble, which would be of great help to us in giving you the best possible customer service.

#### STROBE BULB OUT OR INTERMITTENT:

The bulb probably needs to be replaced. If the bulb flickers or is on part of the time, the problem is not likely to be the circuit, but the bulb itself. Replacement bulb should be a NE-51H or B2A high intensity neon. If they are not available locally, replacements can be ordered from us. To remove the strobe bulb, push it straight in and turn it to the left and it will pop out.

#### STROBE LIGHT ON, TURNTABLE OPERATES, NO VOICE OR MUSIC:

Recheck your speaker hookup to be sure that all terminals are firmly connected, and not worn or corroded. If you are using only the main channel, plug into the monitor channel to see if it operates.

If this problem occurs while you are using only one speaker, if possible check the same speaker with another cord and the same cord with another speaker, to see if the problem is in the speaker, the cord, or the amplifier.

If this should occur while you are using two or more speakers with a series Y connector, remove the Y connector and check each speaker and cord individually by plugging one speaker at a time directly into the amplifier. This will determine if the problem is in one of the speakers, one of the cords, the Y connector, or in the amplifier itself. In a series hookup, if one speaker or one cord has a bad connection, you will get no sound at all from the other speakers. By eliminating a faulty component from a series hookup, the rest of the system may be reconnected and will operate properly.

If your cords, speakers, and Y connectors all check out OK, the problem is in the amplifier. If you do these tests before calling us, we can identify and correct your problem much more quickly.

#### MUSIC ONLY--NO VOICE:

Try the other microphone input. If possible, try another microphone and another mic cord before notifying us.

#### VOICE ONLY--NO MUSIC:

**CHANGE NEEDLES.** Check to see if both main and monitor channels are affected. If possible, check the phono channel by connecting a tape recorder, or CD player, to one of the AUXILIARY MUSIC - INPUT jacks to see if it will play through the amplifier. This will determine whether the problem is in the pickup arm or in the amplifier.

#### DISTORTION:

Check to see if both music and voice are distorted. If music only, change needles. If voice only, try another mic input; try a different microphone. Check to see if both the main and monitor channels are affected. If both voice and music are distorted, check if possible with another speaker. If using two speakers check to see if both are distorting.

#### DISTORTION WHILE PLAYING A TAPE OR CD THROUGH THE AC-500:

Try decreasing the volume at the AUX input level control. Also try decreasing the volume at the source - the tape or CD player. Remember that these controls are only to match the signal source to the main Phonograph or Microphone volume controls. Home made tapes are often over recorded - such a tape will always have distortion when played back. Try another tape - with settings left alone - to make certain you are not fighting an over recorded tape.

#### SPEAKER DEAD OR INTERMITTENT:

Recheck all speaker connections. Check the speaker using the monitor channel. Switch cords and speakers to see if the fault is in the speaker or in the cord.

#### ONE CHANNEL DEAD:

Check as above for faulty speaker cord or speaker.

#### AMPLIFIER GOES DEAD:

Check to see if the power switch is on. If it is check the AC hookup and source of power. Take out and check the fuse. **IF USING MORE THAN TWO SPEAKERS, MAKE SURE THAT Y CONNECTORS ARE IN USE AND PROPERLY CONNECTED. MAKE SURE THAT NO TAPE RECORDER IS CONNECTED TO ANY SPEAKER OR SPEAKER SOCKET.** If the amplifier is hot, wait until it cools before restarting it, with no speakers connected.

### **REMOVING THE AMPLIFIER FROM THE CASE**

Slide a screwdriver under the chrome handle cover and snap it off, exposing the two bolts which hold the handle in place. Remove these bolts. On the opposite side of the unit, locate the two rubber feet. Remove the bolts that hold these feet in place.

Make sure the tone arm is locked in its clip. Lift out the platter, and set it aside.

Turn the set on its right side and pull the front of the chassis away from the case about 3 or 4 inches **CAUTION!** - PULLING THE FRONT OUT TOO FAR AT THIS TIME COULD DAMAGE THE POWER SUPPLY.

Push the back forward just far enough to clear the RCA jack on the rear. Pull the back out until it **JUST** clears the case. There are two cables plugged into the power supply, note the location of the plugs and unplug them. The power supply will remain in the case. Slide the chassis to the right and out of the case.

# MULTIPLE SPEAKER HOOKUP DIAGRAMS

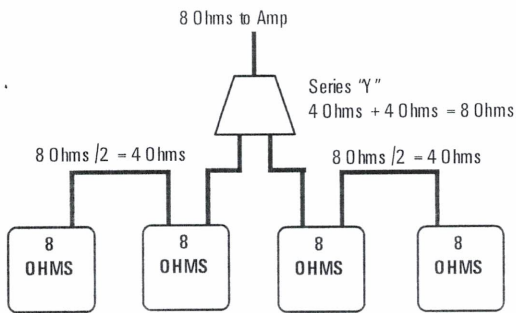
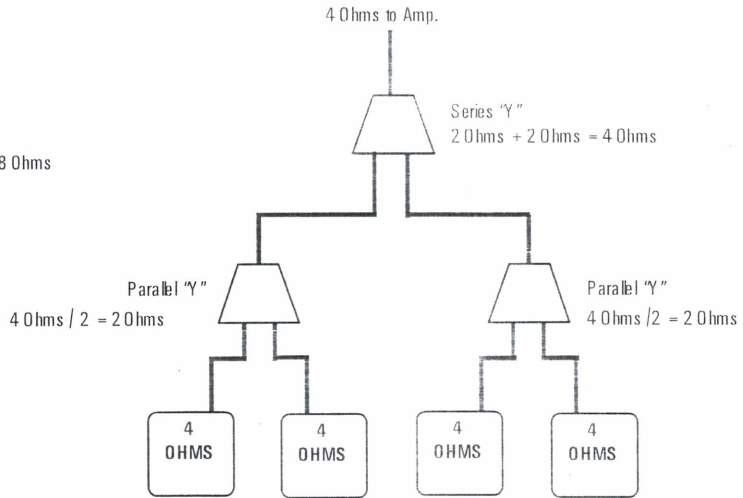
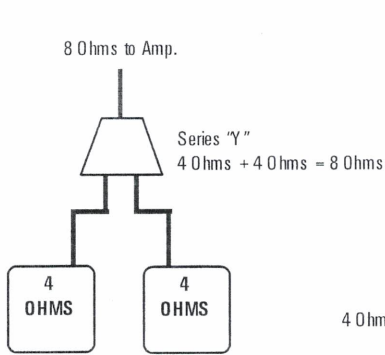

It is not recommend to mix speakers of different types, impedance, or make. Different types and makes have different degrees of efficiency and will produce different sound levels when driven at the same amplifier output

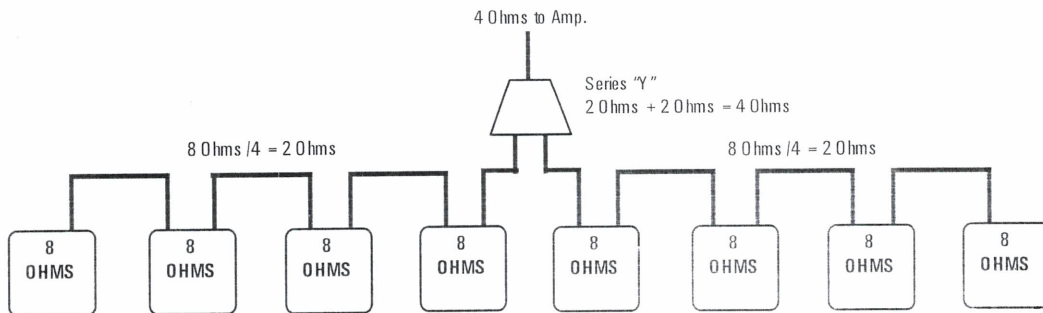
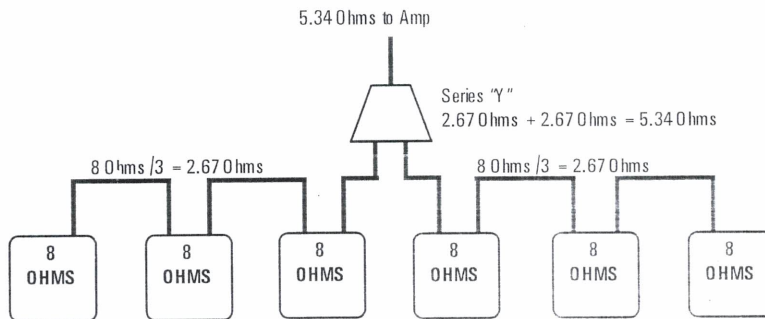

# POWER AMPLIFIER SCHEMATIC

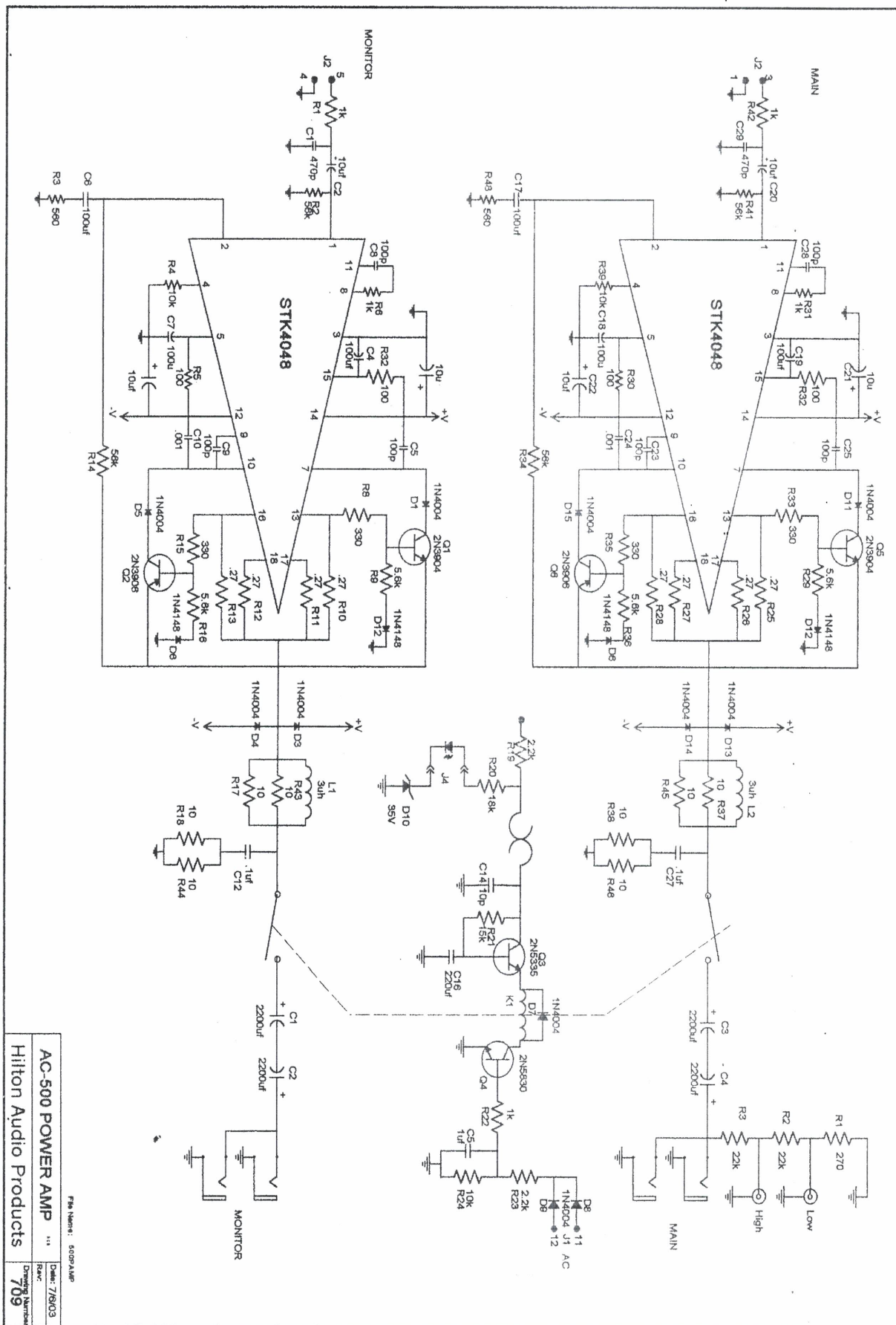

**AC-500 POWER AMP**  
 Hilton Audio Products  
 Part No: 79A03  
 Rev: 7/90  
 Drawing Number: 709

# LED DISPLAY SCHEMATIC

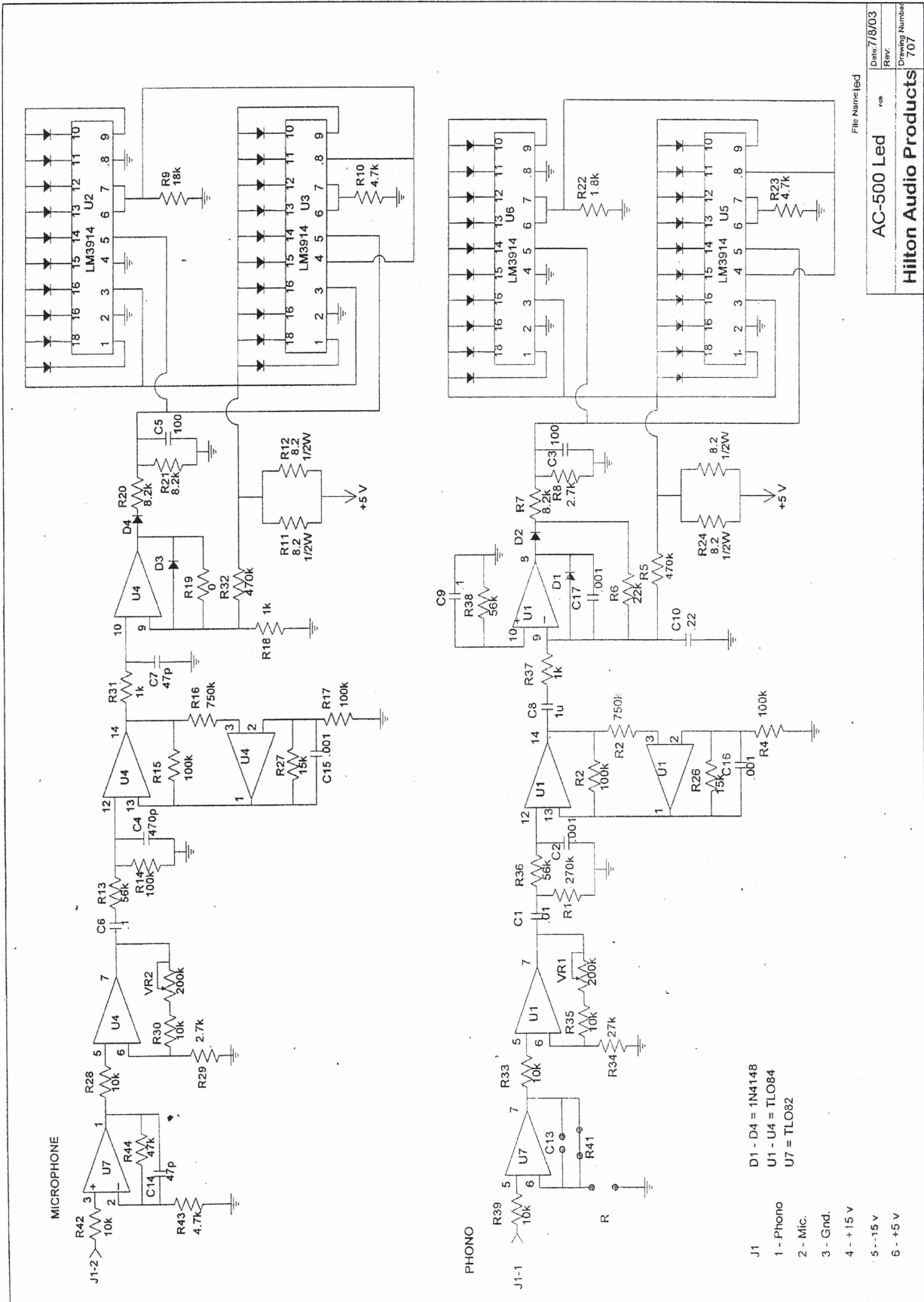

File Name/led	Rev.
AC-500 Led	707
<b>Hilton Audio Products</b>	
Date: 7/8/03	Drawing Number
Rev.	707

# MICROPHONE PREAMPS SCHEMATIC

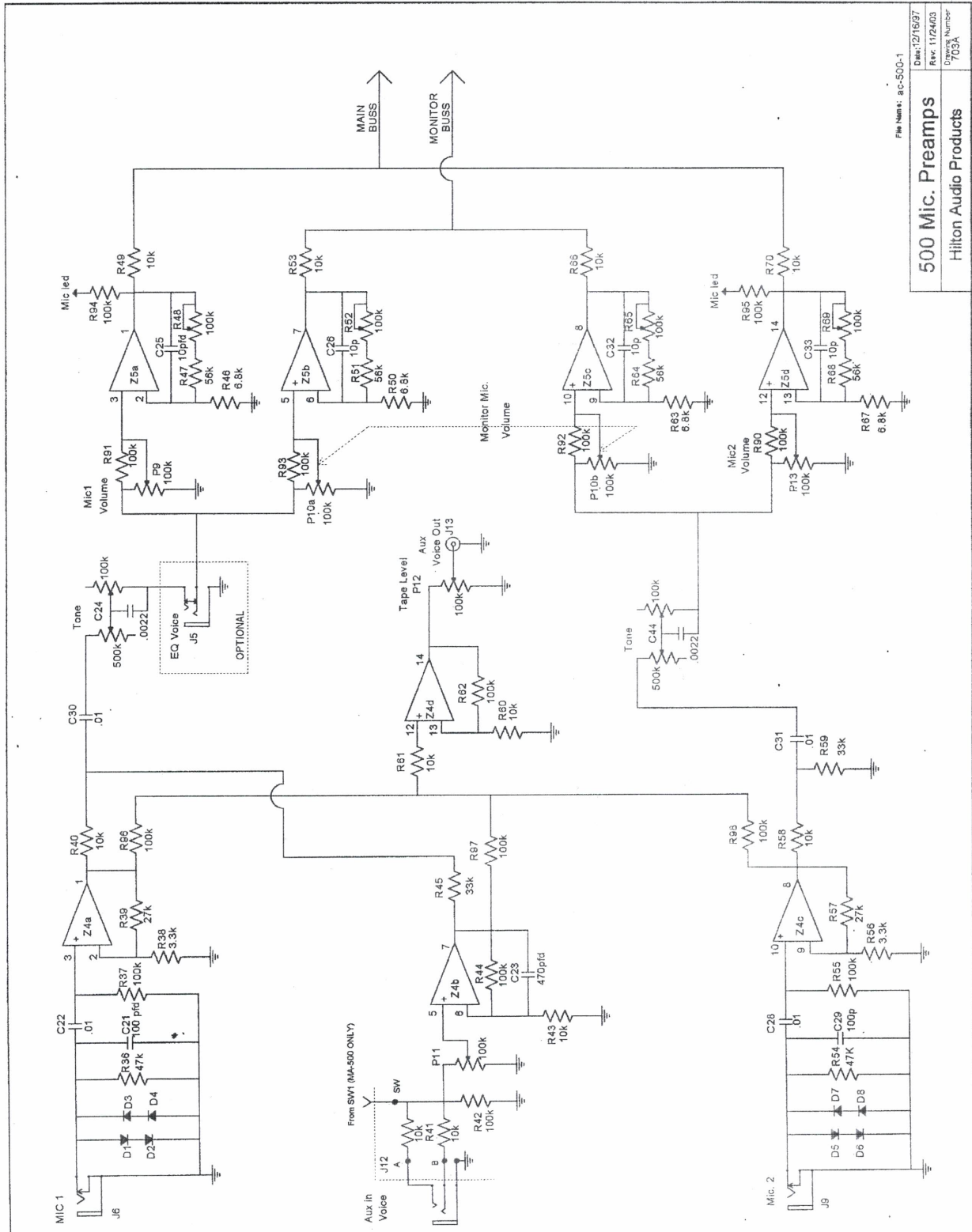

File Name: 81c-500-1

Date: 12/16/87
Rev: 11/24/83
Drawing Number: 703A
<b>500 Mic. Preamps</b>
Hilton Audio Products

# POWER SUPPLY SCHEMATIC

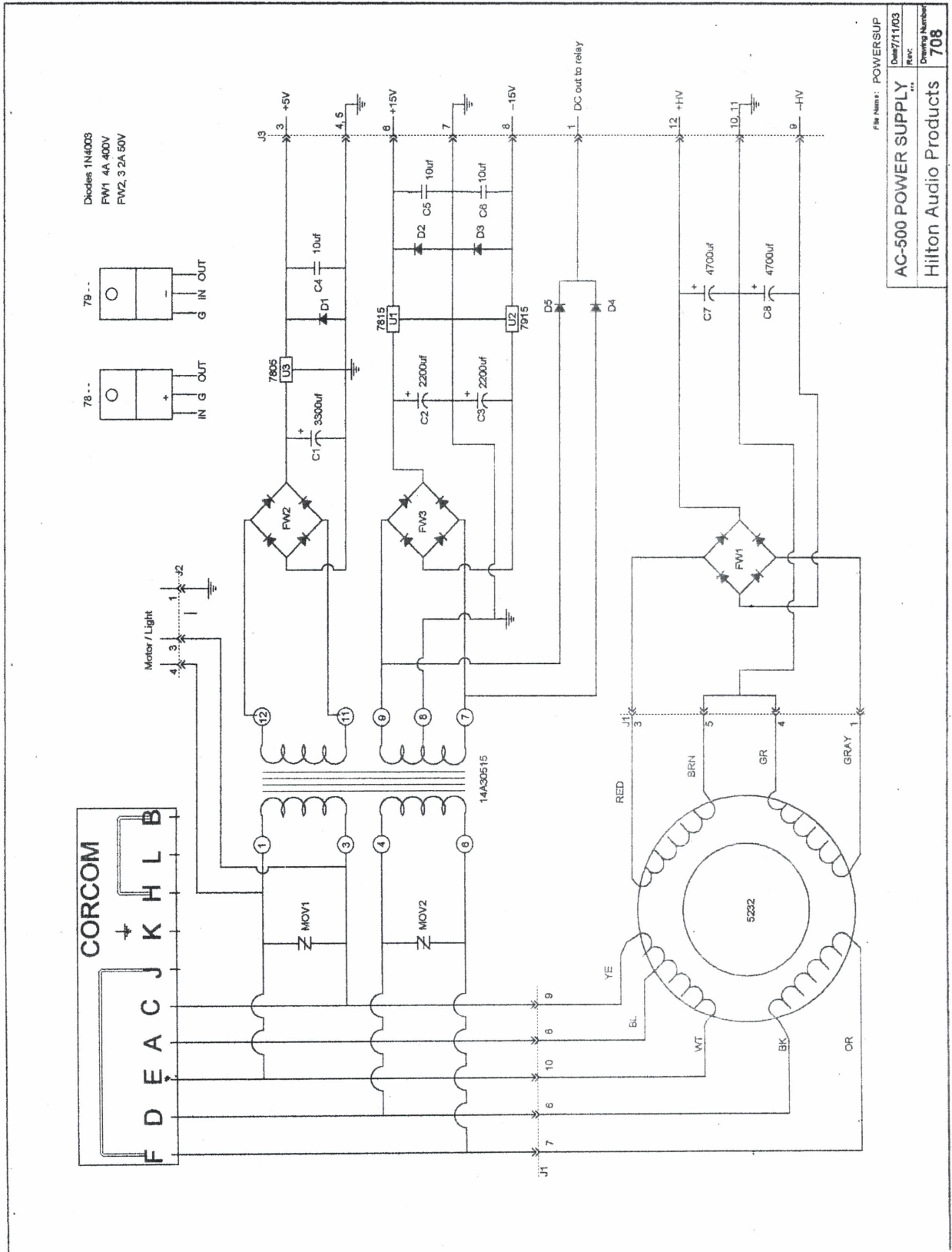

File Name: POWERSUP  
 Date: 7/11/03  
 Rev: ...  
 Drawing Number: **708**  
**AC-500 POWER SUPPLY**  
 Hilton Audio Products



# PHONO PREAMPS SCHEMATIC

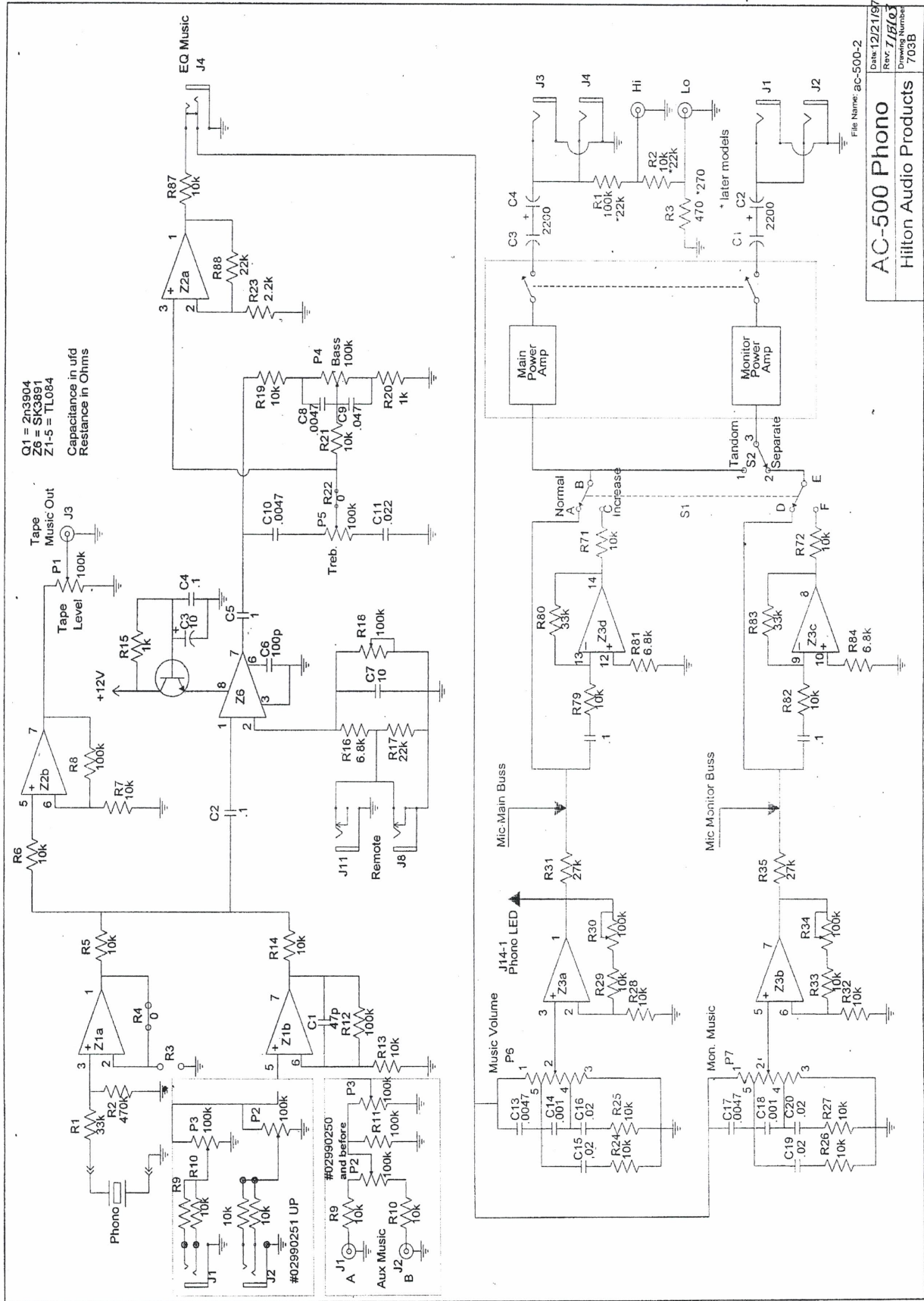

Date: 12/21/97  
 Rev: J/E/03  
 Drawing Number: 703B

**AC-500 Phono**  
 Hilton Audio Products

# LIFTER SCHEMATIC

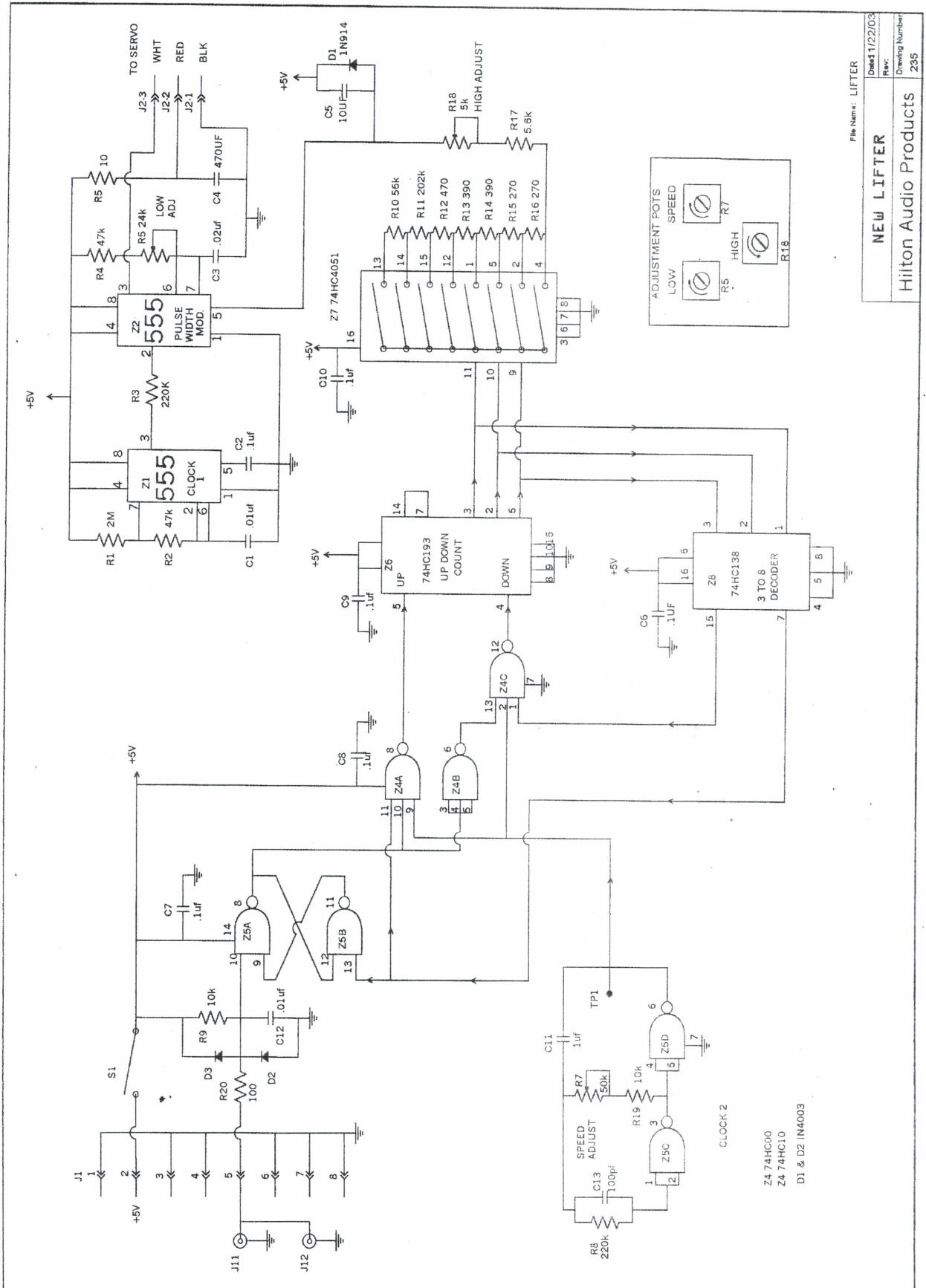

File Name: LIFTER

Date: 1/22/03
Rev: _____
Drawing Number: 295
<b>NEW LIFTER</b>
Hilton Audio Products

- Z4 74HC00
- Z6 74HC193
- Z8 74HC138
- D1 & D2 1N4003